

# LOAD BREAK SWITCH CUBICLE 36kV

Assembly, Operating and Maintenance Instructions

METAL ENCLOSED MODULAR SWITCHGEARS  
(MMM) USER GUIDE



**Switching The Future...**



EVA ELEKTROMEKANİK SAN. VE TİC. LTD. ŞTİ.  
DAĞYAKA MAH. 2008. CAD. NO:5 KAHRAMANKAZAN, ANKARA, TÜRKİYE  
Tel: +90 312 811 27 27 Fax: +90 312 811 27 28  
[www.evaelektromekanik.com](http://www.evaelektromekanik.com)

# CONTENTS

<b>1. GENERAL FEATURES</b>	<b>2</b>
1.1 GENERAL SECTIONS	2
1.2 STANDARDS	2
1.3 CHARACTERISTIC FEATURES	3
<b>2-LOADING - UNLOADING - TRANSPORTING</b>	<b>4</b>
2.1 TRANSPORTING WITH FORKLIFT	4
2.2 TRANSPORTING OVER THE PIPE	4
2.3 TRANSPORTING BY LIFTING SLING	5
<b>3 - INSTALLATION</b>	<b>5</b>
3.1 - TOOLS LIST REQUIRED DURING INSTALLATION	5
3.2 - MATERIALS LIST SENT WITH THE CUBICLE	5
3.3 - CUBICLE'S PLACEMENT	6
3.4 - CONNECTING THE CUBICLES TO EACH OTHER	7
3.5 -MAIN BUSBARS CONNECTION	8
3.6 - EARTHING BUSBARS CONNECTION	9
3.7 - CONNECTING THE CUBICLES' ARRAY TO THE MAIN GROUNDING SYSTEM OF THE FACILITY	9
3.8 -PASSAGES OF AUXILIARY SERVICE AND CONTROL CABLES FROM CUBICLE TO ANOTHER	10
3.9 - CONNECTION OF MV CABLES	11
3.10 - MATTERS TO BE CONSIDERED AGAINST INTERNAL ARC WHEN THE CUBICLE IS MOUNTED	11
<b>4 - COMMISSIONING</b>	<b>12</b>
4.1 - CHECKS TO BE PERFORMED BY THE BARE EYE	12
4.2 - MECHANICAL CHECKS	13
4.3 - SUPPLYING VOLTAGE TO THE MAIN BUSBAR AND REQUIRED CHECKS	13
4.4- OPERATING THE LOAD BREAK SWITCH CUBICLE	13
4.5- SHUTTING DOWN THE LOAD BREAK SWITCH CUBICLE	16
<b>5 - MAINTENANCE INSTRUCTIONS AND RECOMMENDATIONS FOR THE AIR INSULATED METAL ENCLOSED CUBICLES MMMH TYPE</b>	<b>17</b>
5.1-MAIN BUSBAR COMPARTMENT	17
5.2-SF6 GAS INSULATED DISCONNECTORS AND SF6 GAS INSULATED LOAD BREAK SWITCHES	18
5.3 -MECHANISMS' CONTROL	18
5.4 -RELAY AND METERING TOOLS	18
5.5 -EARTHING CIRCUIT	18
5.6-LV COMPARTMENT	18
5.7 MECHANICAL INTERLOCKING SYSTEM	18
5.8 AUXILIARY POWER SUPPLY	19
5.9 LIST OF TOOLS REQUIRED DURING MAINTENANCE AND INSTALLATION	19
<b>6 - GUARANTEE TERMS</b>	<b>19</b>

# 1- GENERAL FEATURES

## 1.1 GENERAL SECTIONS

eva-36-S is an sf6 gas insulated switchgear used for medium voltage distribution networks. eva-36-S, and as desired, can be supplied in a combined form. By performing all the required tests and the related quality control processes to all the modulars, the products will be ready for delivery and installation.

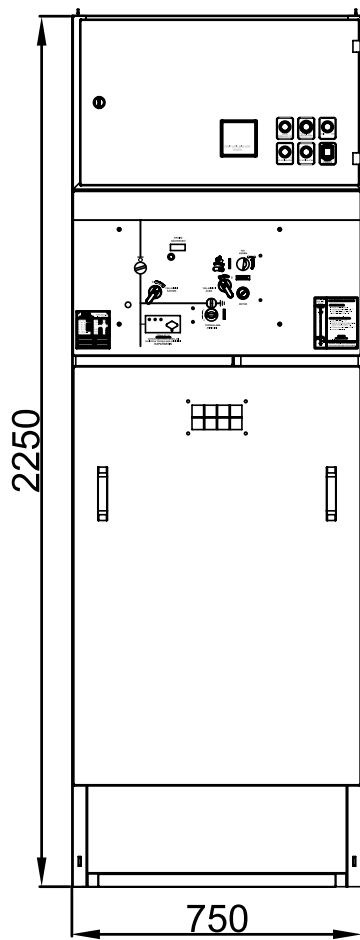

**FRONT VIEW**

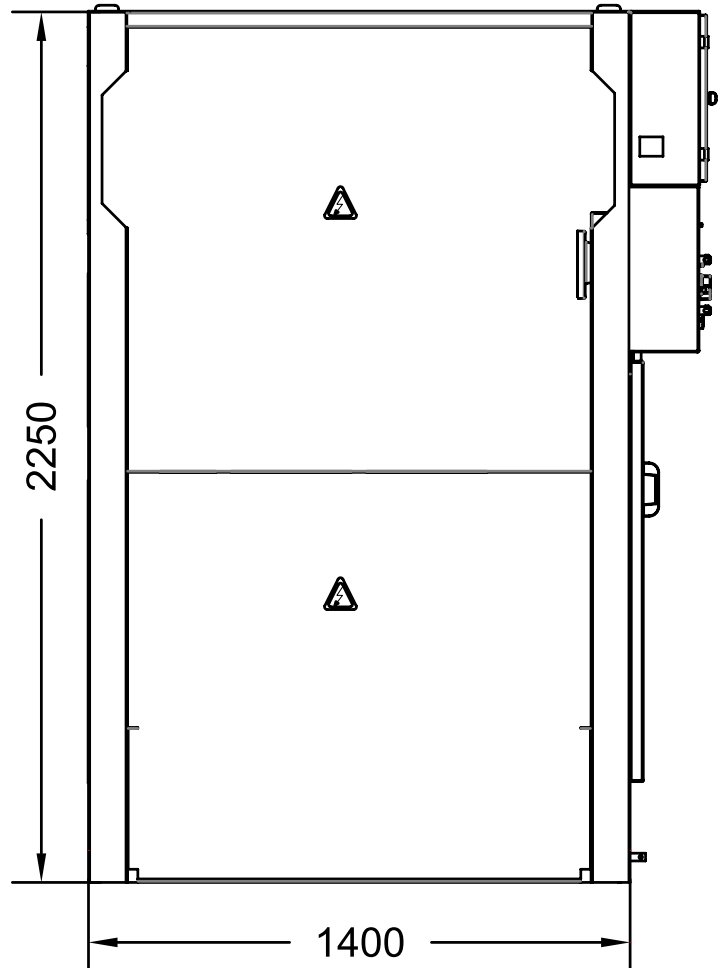

**SIDE VIEW**

## 1.2 STANDARDS

eva-36-S SWITCHING SYSTEM IS FULLY COMPLIANT WITH TS EN / IEC 62271-1, TS EN / IEC 62271-200 STANDARDS. ALSO, THIS SWITCHING SYSTEM HAS A PROTECTION CLASS OF IP3X ACCORDING TO TS EN / IEC 60529 STANDARDS.

TO INSTALL, OPERATE AND MAINTAIN THIS EQUIPMENT SAFELY, TSE AND IEC REGULATIONS MUST BE FOLLOWED.

### 1.3 KARAKTERİSTİK ÖZELLİKLER

Rated Voltage (kV)	36
Type	eva-36-S
Main Busbar Rated Current (A)	630 – 1250
Feeder Rated Current	630 – 1250
Rated power frequency withstand voltage (KV rms)	70
Rated Lightning Impulse Withstand Voltage (kV)	170
Rated Short Circuit Withstand Current (rms)	16kA / 1sec
Rated Peak Withstand Current (kA-Peak)	40
Loss of Service Continuity Class	LSC 2A – PI *
Internal Arc Classification (Cable Connection and Main Busbar)	IAC – A(FL) 16kA / 1sec
Protection Level (TS 3033 EN 60529)	IP3X
Applied Standard	TS EN / IEC 62271-1, TS EN / IEC 62271-200
Height (mm)	2250
Width (mm)	750
Depth (mm)	1400

<b>* LSC 2A - PI DESCRIPTION</b>	
LSC 2A	Loss of Service Continuity
2A	When Interfering to the Accessible Part of a Cubicle like the Cable Connection Compartment and de-energizing it, Neighboring Cubicles May Be Still Energized. In other words, Service Continuity is Not Restricted.
PI	P: There Are Multiple Sections. I: These Sections Are Separated From Each Other By Insulating Material.

## 2- LOADING - UNLOADING - TRANSPORTING

Loading, unloading and transporting methods of the MMMH type cubicles are shown below:

### 2.1 TRANSPORTING WITH FORKLIFT

Cubicles can be carried either way as shown in the the pictures below. In addition, forklift is usually used to unload the cubicles from the truck and transport them to the assembly site.

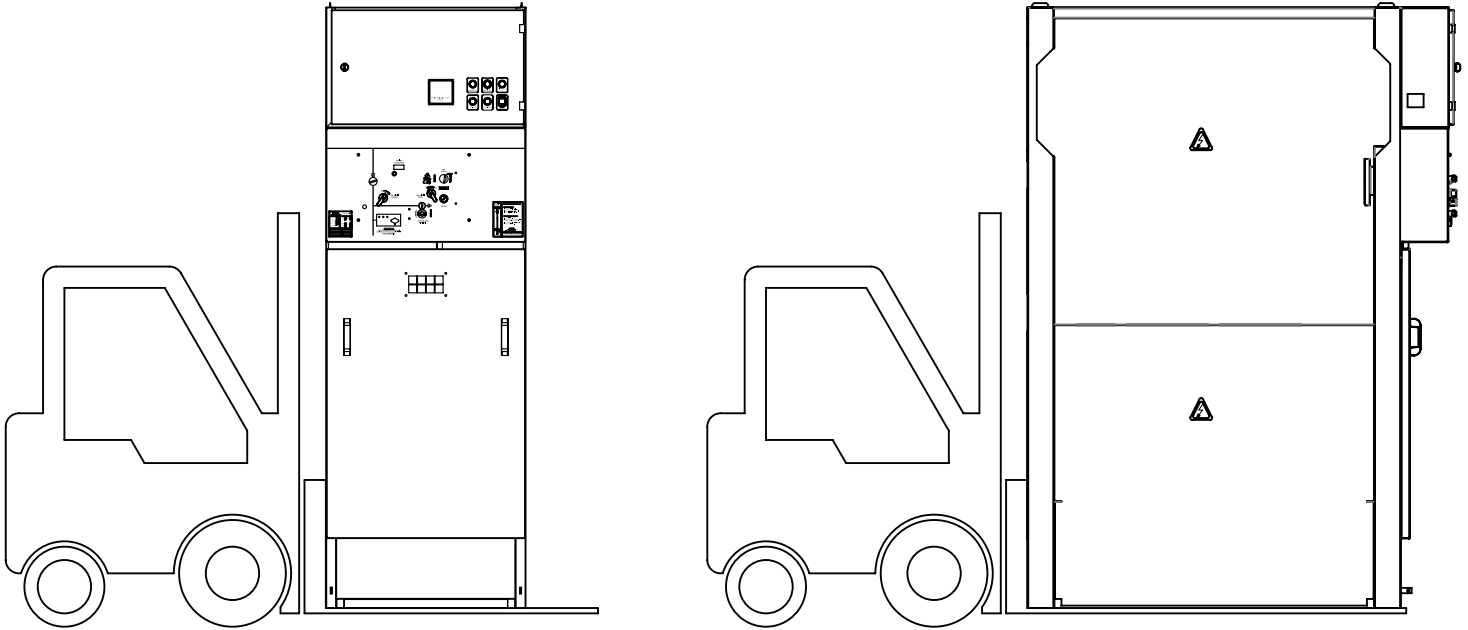

### 2.2 TRANSPORTING OVER THE PIPE

Pipe Transporting is used to line up and dock the cubicles. Never use Cranks while transporting the cubicles.

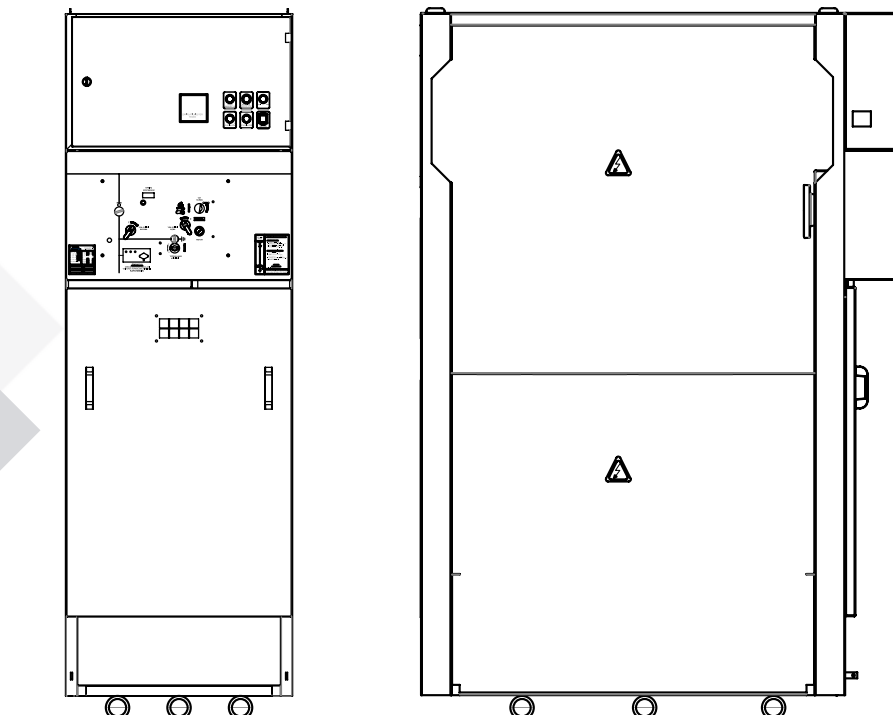

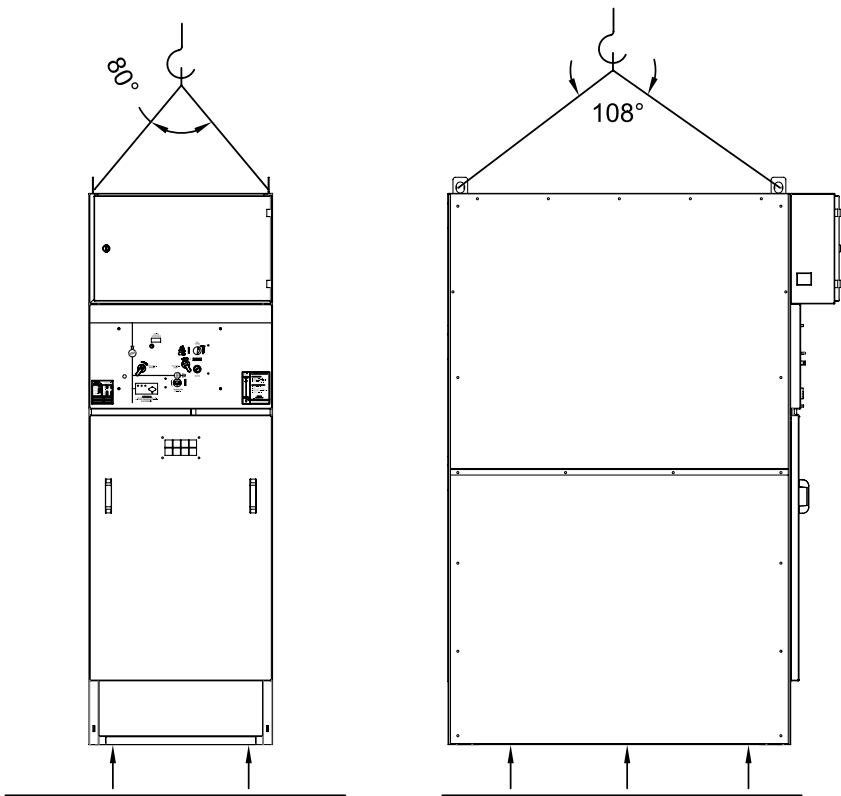

### 2.3 TRANSPORTING BY LIFTING SLING

Cubicles can be transported with the help of sling lifting by means of a crane. Usually it is used while unloading the cubicles from the truck.

## 3 - INSTALLATION

### 3.1 - TOOLS LIST REQUIRED DURING INSTALLATION

Tools	Dimensions	Quantity
Open End Wrench	10"	2 Pcs
Open End Wrench	13"	2 Pcs
Open End Wrench	15"	1 Pcs
Open End Wrench	17"	1 Pcs
Open End Wrench	19"	1 Pcs
Open End Wrench	24"	1 Pcs
Torque Wrench	-	1 Pcs
Socket Wrench	-	1 Pcs
Socket	10", 13", 15", 17", 19", 24"	1 Pcs
Plumb bob	-	1 Pcs
Crank	-	1 Pcs

### 3.2 - MATERIALS LIST SENT WITH THE CUBICLE

Materials	Quantity
M8x20 Flange bolt	15 Pcs
M8 Nut	15 Pcs
Operating Lever	1 Pcs
Main Busbar	3 Pcs
Earthing Busbar	1 Pcs
Remote control	1 Pcs

### 3.3 - CUBICLE'S PLACEMENT

#### 3.3.1 Placement inside the Building:

- Place the MMMH Type cubicle on a channel inside the building in accordance with the dimensions indicated in the right picture.
- A 5cm gap should be left between the placed cubicles on the right or the left side inside the building and the wall.
- Close the channel gaps.
- Do not go below the dimensions indicated in the right picture.

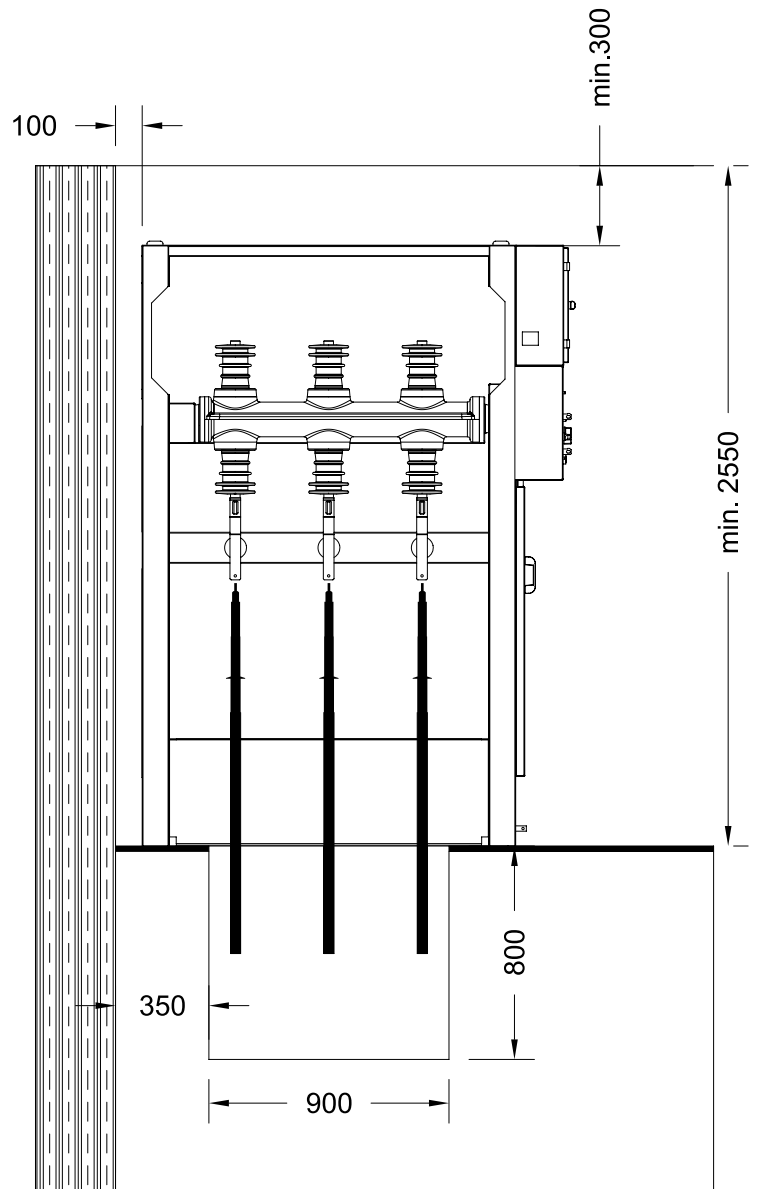

- Base holes that enable the cubicles to be fixed to the ground are provided as shown in the below picture.
- Fix the cubicles to the ground by using M10 steel peg or iron dowel.

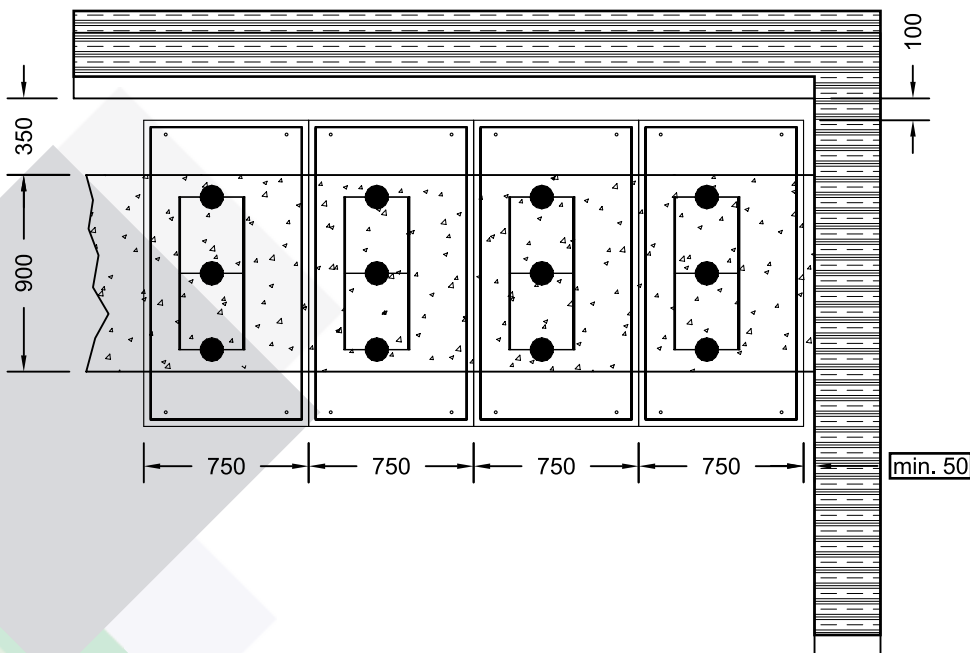

#### IMPORTANT WARNING:

- The dispatched cubicles should be placed on the side and according to the illustrated figure.
- Do not go below the provided dimensions.
- The building dimensions can be determined accordingly.
- The gaps between the cubicles from one side and the ceiling and the back wall from the other side should be at least 300mm and 100mm respectively.



### THE BASE METAL HOLE DIMENSIONS OF THE CUBICLE

The lower holes dimensions are provided in the picture below. Based on these dimensions a steel peg or an iron dowel should be used. Then the holes to be fixed with M10x50 bolts.

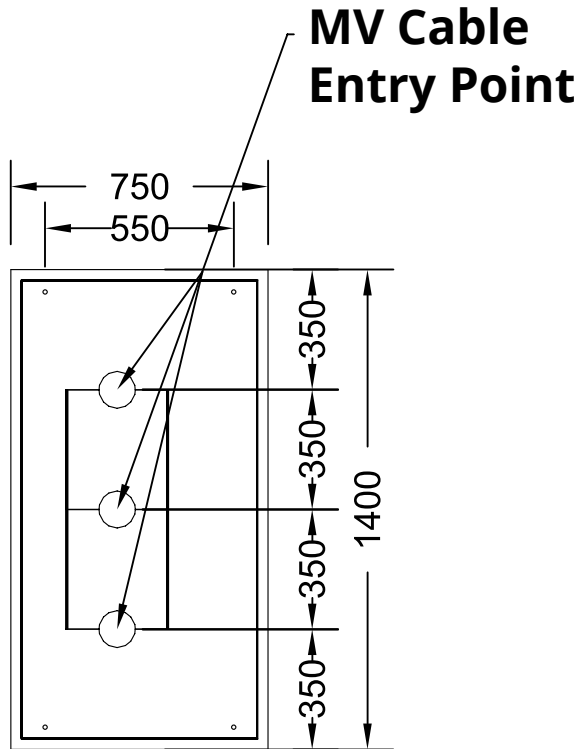

### 3.4 - CONNECTING THE CUBICLES TO EACH OTHER

Pull the lifting hooks upwards (See below pictures). Bring the cubicles to the settlement area by using the relevant transport apparatus and taking into consideration the "Loading - Unloading Transporting" instructions.



In accordance with the single line diagram of the facility, combine the square-shaped holes of the cubicles side by side using M8x20 bolts. See the below picture (1).



**IMPORTANT WARNING:** If the surface on which the cubicles will be mounted is not flat, the cubicles' covers may not be fitted properly and also problems may be caused in the main busbar connection.

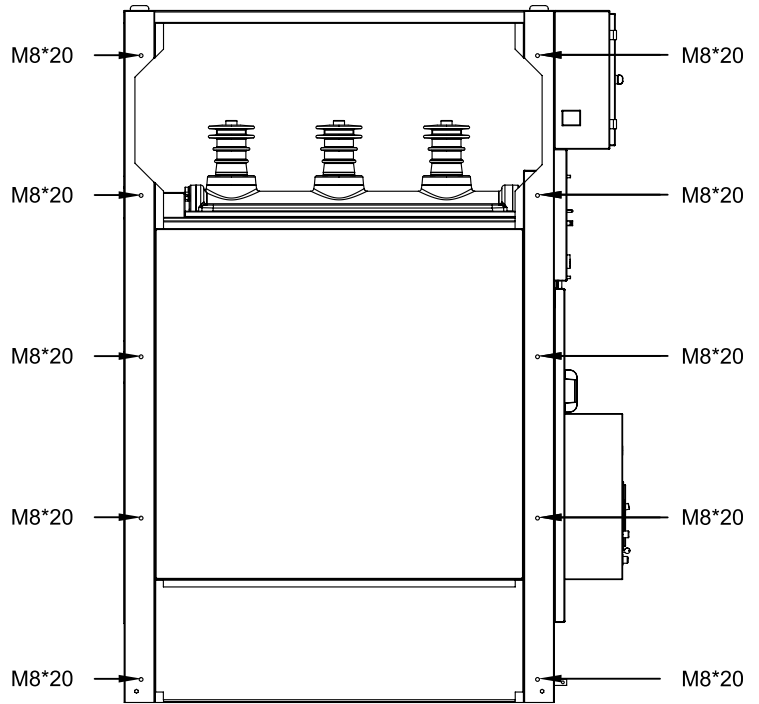

### 3.5 -MAIN BUSBARS CONNECTION

MAIN BUSBAR TYPES:

MAIN BUSBAR CURRENT AND THICKNESS		
Busbar Material	630 A	1250 A
Copper (Cu)	40x5 mm <sup>2</sup>	60x10 mm <sup>2</sup>
Aluminum (Al)	40x10 mm <sup>2</sup>	*

\* Aluminum Busbar is not used when the Main Busbar Current is 1250A .

1. According to the "3.3- CUBICLE'S PLACEMENT" article stated above, remove the upper cover plate of the connected cubicles.
2. Connect the main busbars shipped with the cubicles to the main bus terminal using field regulators and tighten the bolts with 50Nm torque.
3. Wipe the insulators and solid insulation materials with a dry clean cloth.
4. Assemble the upper cover plate.



**IMPORTANT WARNING:** Do not step or walk on the main busbars, disconnectors and load break switches.

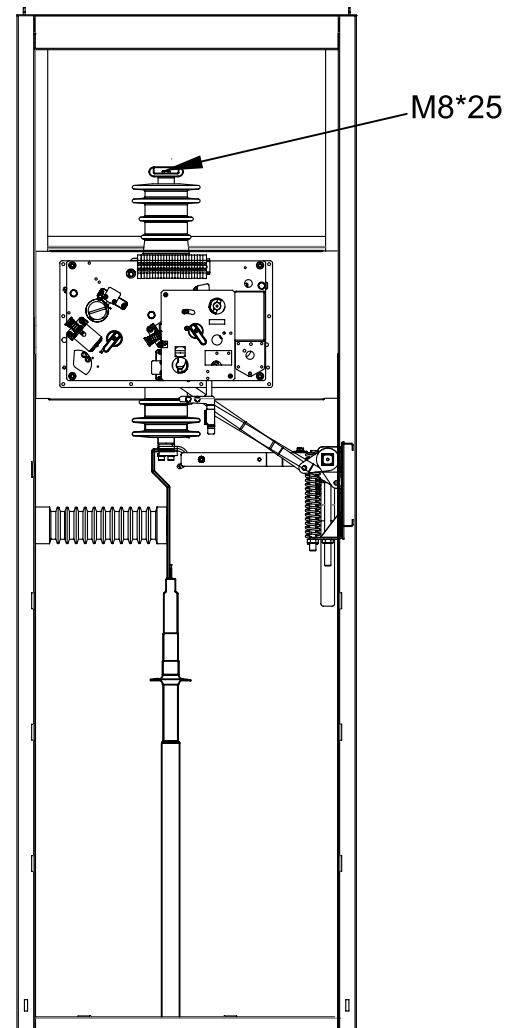

### 3.6 – EARTHING BUSBARS CONNECTION

Connect the grounding busbar points of the two adjacent cubicles with a copper conductor that is already provided with the cubicle using bolts as shown in the right picture (3).

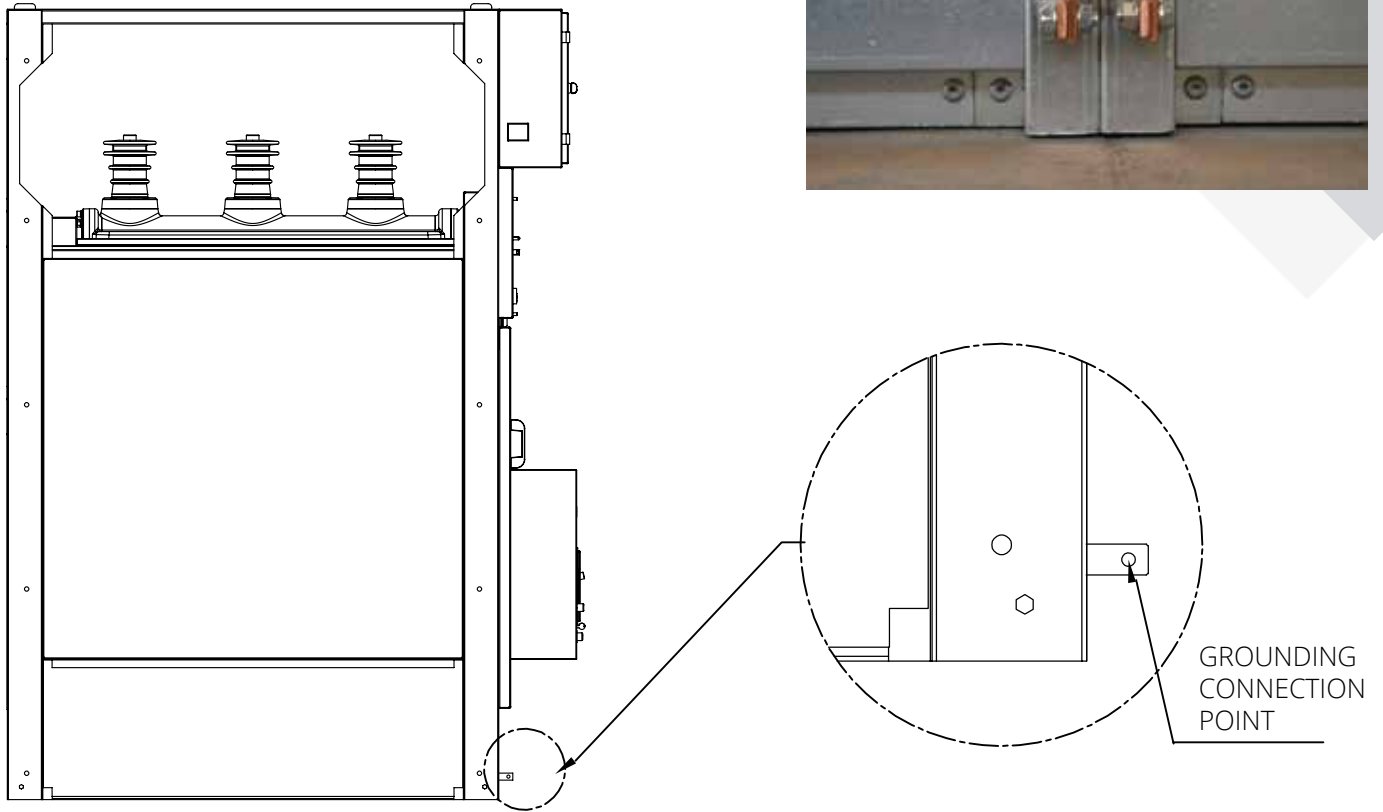

### 3.7 - CONNECTING THE CUBICLES' ARRAY TO THE MAIN GROUNDING SYSTEM OF THE FACILITY



- To connect the cubicle's array to the facility's main grounding system, use the grounding busbar located in the cable connection compartment of the cubicles. See Picture (4).
- Any of the cubicles at the beginning or at the end of the cubicle's array can be used for this purpose.



**IMPORTANT WARNING:** Check thoroughly that the grounding busbars of all the cubicles found in the cubicle's array are connected to each other.

### 3.8 – PASSAGES OF AUXILIARY SERVICE AND CONTROL CABLES FROM CUBICLE TO ANOTHER

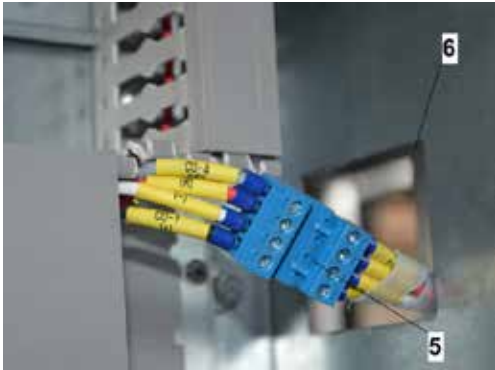

- The sockets in the LV cabinet are used for the passage of auxiliary service and control cables from cubicle to another. See the left picture (5).
- Take either the female or the male socket found on the cable passage hole in the LV cabinet and connect it to its corresponding socket found on the cable passage hole of the next cubicle. See the left picture (6).



**IMPORTANT WARNING:** If there is a battery rectifier group in the facility, ensure that is connected to a 220 / 230 VAC source.

**NOTE:** The cable passage hole found at the very beginning or at the end of the cubicle's array is used for the passage of the auxiliary service, control and command cables coming from the external power supplies.

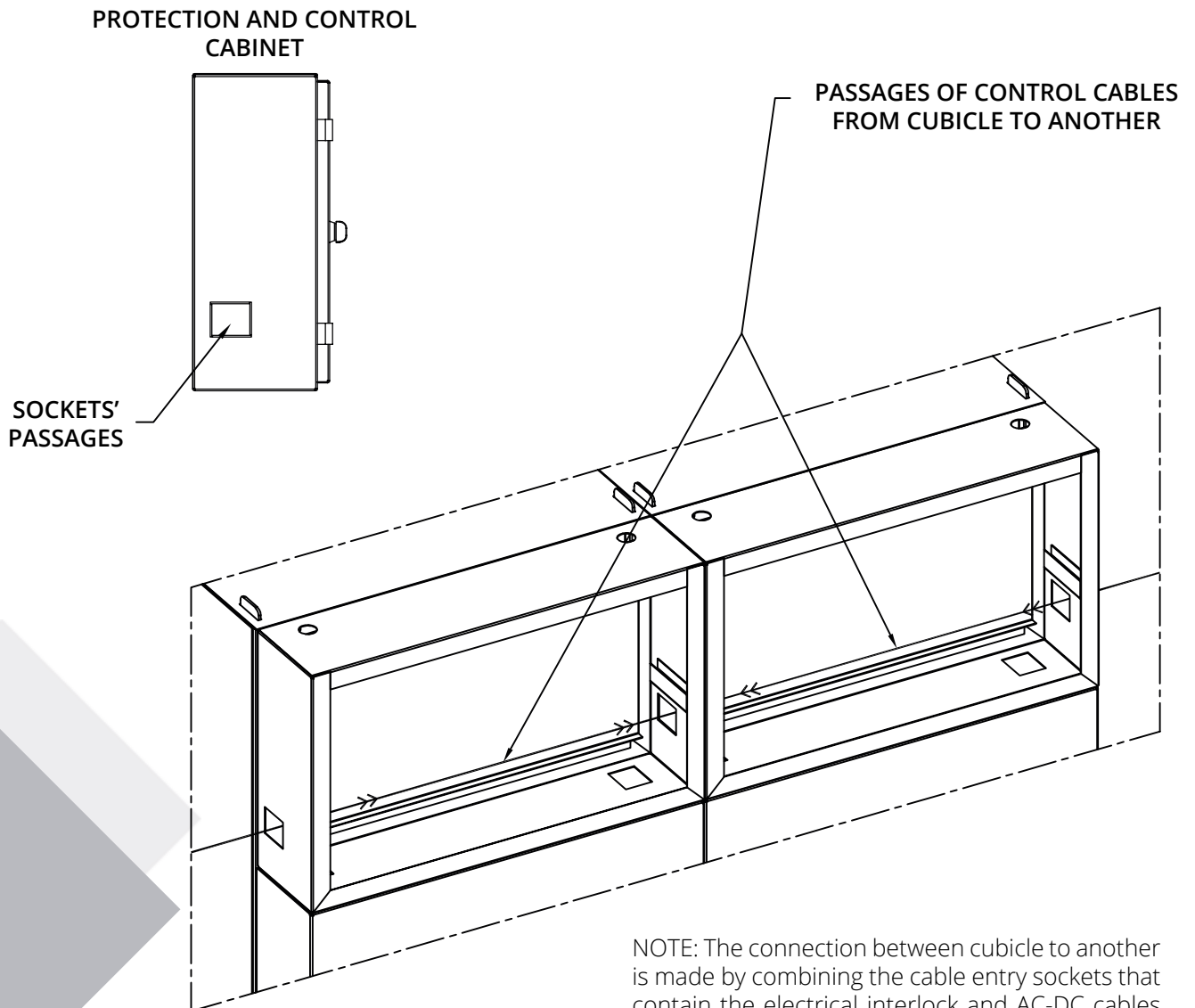

**NOTE:** The connection between cubicle to another is made by combining the cable entry sockets that contain the electrical interlock and AC-DC cables to each other.

### 3.9 - CONNECTION OF MV CABLES

1. Open the cubicle's cable connection compartment door.
2. Mount the cable terminal caps ( internal type ) on the MV cable terminals in accordance with the related instructions.
3. Connect the mounted terminals to the cubicles's output terminals. See picture (7).
4. Connect the metallic screen of the MV cables to the cubicle's earthing busbar.
5. Fix the MV cables by using the cable supporting points located on the MV cables' entrance of the cubicle. See picture (8).



7



8

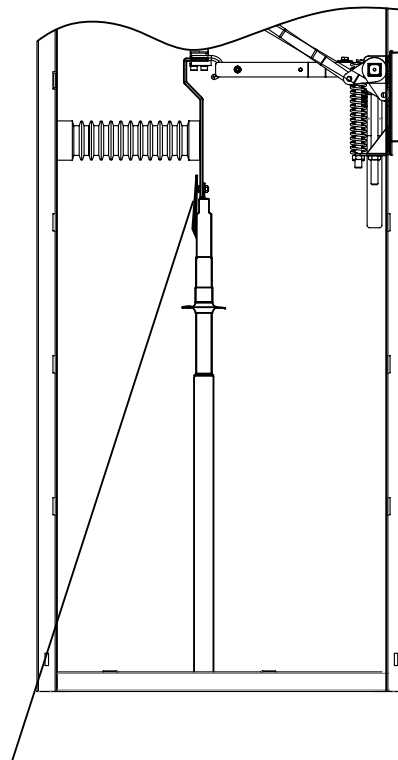

#### MV CABLES CONNECTION

MV Cables are made according to the cable terminal cap instructions. The plastic plugs found at the cubicle's bottom surface should be adjusted in accordance with the cables diameter so to enable the cables from passing through them. See picture (8).

### 3.10 - MATTERS TO BE CONSIDERED AGAINST INTERNAL ARC WHEN THE CUBICLE IS MOUNTED

Close the cubicle's side by cover plates before the operating.

## 4 - COMMISSIONING

If a cubicle array will be formed by arranging various types of MMMH cubicles side by side and the commissioning will be performed for the first time, it is recommended by our company to apply the following procedure:

### 4.1 - CHECKS TO BE PERFORMED BY THE BARE EYE (Checks to be Performed While the Main Busbar is De-energized)

1. Check whether the connections of the cubicles' main busbar are connected along with the disconnecter or the load break switch or not and tighten the loose bolts and nuts if required. While checking the connectivity, be careful from damaging the bushings of the disconnecter or the load break switch. Never step or walk on the busbar, disconnecter or the load breaker switch.
2. To determine that there are no cracks, fractures, carbonization marks or any defects on the bushings' body, wipe it with a dry cloth.

**IMPORTANT WARNING:** Never connect the MV cables connected to the output terminal in a way that will force the output terminals to pull down.

3. Check the conductor connections in the switchgear for the breaker, load break switch, disconnecter, current transformer, etc. by opening the cable connection compartment door of the cubicles and then tighten the loose bolts with 15-20Nm Torque if required. Clean the insulators and solid insulation materials with a dry cloth.
4. Check if there is any unusual object inside the cubicle and take it out.
5. Check that there is at least 100 mm gap between the cubicles' back and the building's wall and that there is no objects in between.
6. Check whether the side cover plates used against the internal arc are fixed, if not fix them so.
7. If there is a battery rectifier group in the facility, ensure that is connected to a 220 / 230 VAC source.
8. Ensure the grounding system of the cubicles by checking the grounding busbars of the cubicles' array which must be properly and tightly connected to each other. Also, ensure the cubicles' grounding system by checking the earthing busbar of the first or the last cubicle which must be connected to the external earthing system by an earthing conductor.
9. Check the connections of the LV cabinet.
10. Ensure the gas level is in between the permissible limit by checking the manometer gas pressure gauge shown below.



## 4.2 - MECHANICAL CHECKS (Checks to be Made in This Section Should Be Performed While the Main Busbar is De-energized.)

1. Perform "Commissioning", "De-commissioning" and the "Accessibility to Cable Connection Compartment" for each cubicle in accordance with the operating instructions stuck on them. During that, check the mechanical interlocks are operating properly and no problems are occurred.
2. Check the equipment's control mechanisms are performing properly and the TRIPPING-CLOSING indicator positions show the right positions.
3. Please contact EVA ELEKTROMEKANİK on (0090 312 811 2727) if any problem is encountered during the above points.

## 4.3 - SUPPLYING VOLTAGE TO THE MAIN BUSBAR AND REQUIRED CHECKS

1. Switch on all the switching elements found on the cubicles' array.
2. By Switching off the switching elements of the incoming cubicle, energize the main busbar and wait for 90 to 120 minutes.
3. Ensure that the voltage indicators lamps of the incoming cubicle are off.
4. If no problems were observed then energize the cubicles one by one as stated below.
5. After energizing the cubicle's array, check whether if there is unusual noise or not.

## 4.4- OPERATING THE LOAD BREAK SWITCH CUBICLE

### LOAD BREAK SWITCH POSITION INDICATOR

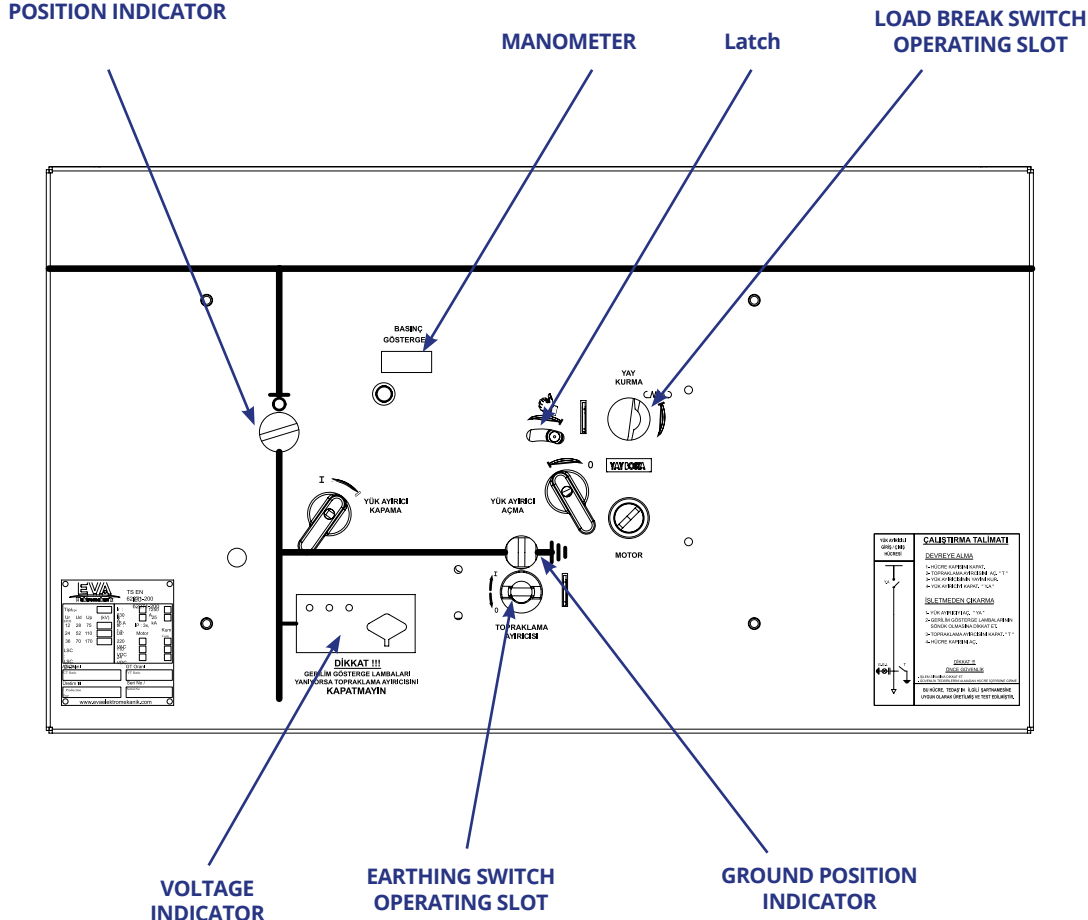



1. If the Cable Connection Compartment door of the Load Break Switch Cubicle is Open, CLOSE it.

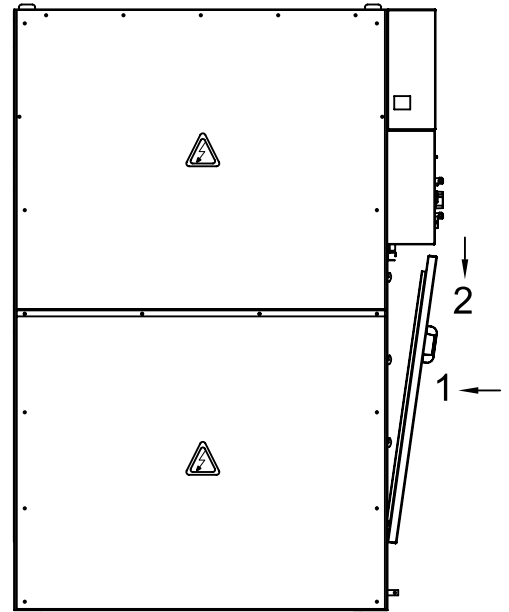

2. Put the Operating Lever into the Earthing Switch Operating Slot and SWITCH ON the Earthing Switch by turning it counterclockwise.



The ground will come into the position shown in the figure.



3. Put the Operating Lever into the Load Break Switch Operating Slot and LOAD the spring by turning it counterclockwise. Take out the Operating lever from the Operating Slot.



The spring will come into the position shown in the figure.





**NOTE: IF THE LOAD BREAK SWITCH IS MOTORIZED:**

Make sure that the spring is loaded (observe the “spring loaded” expression) by turning the motor’s spring loading switch clockwise.



4. SWITCH OFF the Load Break Switch by turning the tipping switch to the “I” position.



5. Ensure that the voltage indicator lamps are on.



## 4.5- SHUTTING DOWN THE LOAD BREAK SWITCH CUBICLE

1. SWITCH ON the load break switch by turning the closing switch to the "0" position.



2. Ensure that the voltage indicator lamps are off.



**IMPORTANT WARNING:** Do not operate until you observe that the voltage indicator lamps are off.

3. Put the Operating Lever into the Earthing Switch Operating Slot and SWITCH OFF the Earthing Switch by turning it clockwise. Confirm that by checking the observation window.



The ground will come into the position shown in the figure.



- If necessary, Open the Cable Connection Compartment door.

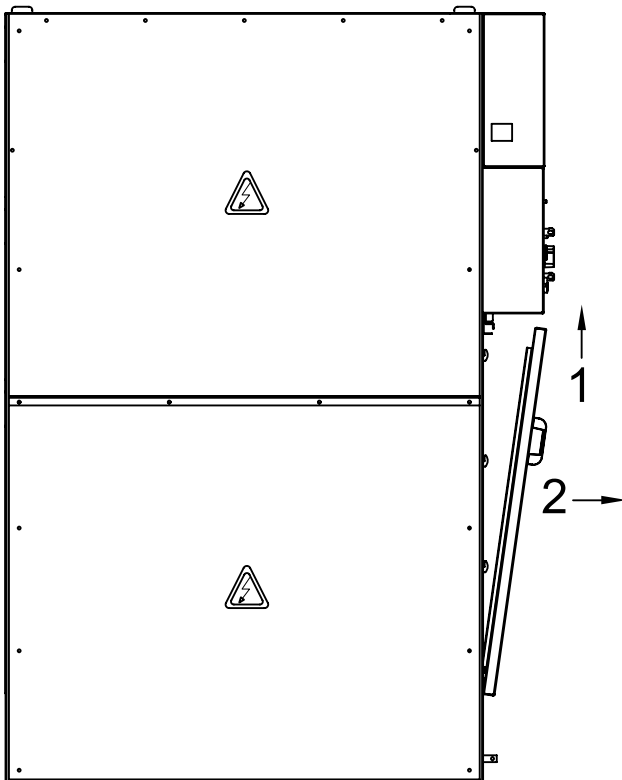

## 5 - MAINTENANCE INSTRUCTIONS AND RECOMMENDATIONS FOR THE AIR INSULATED METAL ENCLOSED CUBICLES MMMH TYPE



**IMPORTANT WARNING:** Before starting the maintenance work; the Cubicles and the Main Busbar must be DE-ENERGIZED and the GROUNDING must be taken too.

### 5.1-MAIN BUSBAR COMPARTMENT

To find the main busbar, remove the bolted connections of the covers found on the upper part of the cubicles.

- Check whether the connections of the cubicles' main busbar are connected along with the disconnecter or the load break switch or not and tighten the loose bolts and nuts if required. While checking the connectivity, be careful from damaging the bushings of the disconnecter or the break switch. Never step or walk on the busbar and the disconnecter or the load breaker switch.
- To determine that there are no cracks, fractures, carbonization marks or any defects on the bushings' body, wipe it with a dry cloth.



Picture-2: Cubicle's Upper Cover Plate

## 5.2-SF6 GAS INSULATED DISCONNECTORS AND SF6 GAS INSULATED LOAD BREAK SWITCHES

In order to find the cables connection points and the equipment lower terminals, open the Cable Connection Compartment Door.

1. Open the Cable Connection Compartment Door. If the door cannot be opened, check whether the door opening method is applied correctly or not.
2. Check the conductors connections between the main circuit and the equipment and tighten the loose bolts and nuts with 15-20Nm Torque if required. While checking the connectivity, be careful from damaging the bushings of the disconnector or the load break switch.
3. To determine that there are no cracks, fractures, carbonization marks or any defects on the bushings' body, wipe it with a dry cloth.
4. Ensure the gas level is in between the permissible limit by checking the manometer gas pressure gauge.
5. Make the earthing switch mechanism controls with the operating lever. Make sure that the mechanism operate properly by checking the observation window. See Picture-1.



Picture-1: Observation Window

## 5.3 -MECHANISMS' CONTROL

1. Check the proper operating of the control mechanisms of all the used equipment and ensure that the indicators show the right positions.
2. M1 type mechanisms should be taken into general maintenance by the manufacturer after 2000 tripping and closing operations while the M2 type mechanisms should be taken after 10000 tripping and closing operations.

Circuit Breaker	M1 (2000 Tripping/Closing), M2 (10.000 Tripping/Closing)
Load Break Switch	M1 (2000 Tripping/Closing)
Disconnecter	M0

## 5.4 -RELAY AND METERING TOOLS

1. Check the connections of the relay and metering devices to the protection box and tighten the loose ones.
2. Check if the relay and metering devices are operating properly.
3. Check the conductors connection and tighten the loose ones.

## 5.5 -EARTHING CIRCUIT

1. Check the continuity of the cubicles grounding circuit and tighten the loose bolts and nuts. Ensure that the resistance between the grounding terminal and the metal body is 0.1 ohm at most.
2. Check the cubicle ground terminals which are arranged side by side are properly and firmly connected to each other and all the cubicles are connected to the main grounding system with a common grounding conductor.

## 5.6-LV COMPARTMENT

1. Open the LV Compartment Cover and clean the inside area.
2. Check if there is defective insulation in the control circuit and fix it.
3. Check the terminal connections and tighten the loose ones.

## 5.7- MECHANICAL INTERLOCKING SYSTEM

Check if the cubicals mechanical interlocking system is operating properly.

### 5.8- AUXILIARY POWER SUPPLY

Check the auxiliary power supply (if any).

#### FREQUENT MAINTENANCE



- General maintenance to be made at least every two years.
- It is recommended by our company for cubicals's solid insulation materials used in VERY DIRTY environments to be checked and cleaned once a year at latest.

### 5.9 LIST OF TOOLS REQUIRED DURING MAINTENANCE AND INSTALLATION

Tools	Dimensions	Quantity
Dirt Chemical Solution	-	-
Clean Cloth	-	-
Avometer	-	1 Pc
Main Circuit Resistance Metering Tester	-	1 Pc
Open End Wrench	10", 13", 15', 17", 19", 24"	2 Pc
Torque Wrench	-	1 Pc
Socket Wrench	-	1 Pc
Socket	10", 13", 15', 17", 19", 24"	1 Pc

## 6 - GUARANTEE TERMS

The manufacturer company guarantees the product against any material and operational defects for a period of 2 years within the conditions specified in the contract. In this 2-years period, if any malfunction is detected within the conditions specified in the contract, the manufacturer company may seek repair and / or replacement of the faulty products. Improper storage, use or repair of the equipment by the user other than the conditions specified in this user manual, constitutes a breach of the warranty and causes it to be null.

**NOTES:**

A series of horizontal dotted lines for writing notes.

**Switching The Future...**

**EVA**  
**Elektromekanik**



evaelektromekanik  
[www.evaelektromekanik.com](http://www.evaelektromekanik.com)



EVA ELEKTROMEKANİK SAN. VE TİC. LTD. ŞTİ.  
DAĞYAKA MAH. 2008. CAD. NO:5  
KAHRAMANKAZAN, ANKARA, TÜRKİYE  
Tel: +90 312 811 27 27 Fax: +90 312 811 27 28  
[www.evaelektromekanik.com](http://www.evaelektromekanik.com) [satis@evaelektromekanik.com](mailto:satis@evaelektromekanik.com)

**METAL ENCLOSED MODULAR SWITCHGEARS  
(MIMMH) USER GUIDE**